

A GENERALIZED AIR INTERFACE AS A POTENTIAL SPACE-TO-GROUND STANDARD

Harvey Berger, Mark Bever, and Reginald Jue
TRW Space & Electronics, One Space Park, Redondo Beach, California 90278, USA
Phone: +1 310 813 7692, e-mail: harvey.berger@trw.com
Marketing Contact: Joe Freitag, e-mail: joe.freitag@trw.com
Visit our website at <http://www.trw.com/broadband>

ABSTRACT

This paper describes a generalized air interface between spacecraft and ground terminals including modulation, coding, and frame formats. Both the uplink and downlink employ adaptive coding offering significant coding gain, low sideband modulation to mitigate adjacent channel interference, and low overhead frame formats. The trades leading to the selection of these modulations, coding, and frame formats will be described as well as coding options available to achieve a range of uplink and downlink coding gains.

INTRODUCTION

Several emerging Ka-Band satellite systems have selected asynchronous transfer mode (ATM) protocols for their uplinks and downlinks. This paper describes a generalized air interface employing adaptive coding that offers a menu of selectable coding gains, low adjacent channel interference, and a low overhead frame format based on a standard, flexible network protocol that is compatible with ATM. This paper also defines the system under consideration, describes desirable characteristics of an air interface, and proposes the radio frequency (RF) modulation, coding, and frame format providing a balance among these metrics.

SYSTEM OVERVIEW

The system architecture considered is a multi-beam Ka-Band communication system incorporating a regenerative (i.e., processed) payload (Figure 1). This payload performs onboard signal demodulation, decoding, routing, and other necessary processing before encoding and remodulating the signal for downlink transmission. While designed for Ka-Band ground-to-satellite links, the proposed interface may also be applied to systems operating with bent-pipe satellites and in other frequency bands.

INTERFACE METRICS

From the user's perspective, ideal communications system attributes are low cost, high reliability, full compatibility with external protocols, and common interfaces with multiple communications providers. These basic attributes were used to derive a set of metrics for the space-to-ground interface. Some of these metrics include:

- **Bandwidth Efficiency: A Key Characteristic**—Bandwidth efficiency goes beyond the traditional bits/Hz metric and implies maximizing useable throughput within a given frequency band. It has implications in many aspects of the system. In addition to driving the modulation and coding techniques, bandwidth efficiency also dictates frequency reuse—driving the system to spot beam implementation. This, in turn, drives the modulation to have low levels of self-interference.

The ideal communications system allows for variable data rates to permit flexible allocation of bandwidth. In this way, only as much bandwidth need be allocated as required by the particular connection. This may be accomplished by a combination of variable channel bandwidths in a frequency division multiple access (FDMA) structure, and allocation of time

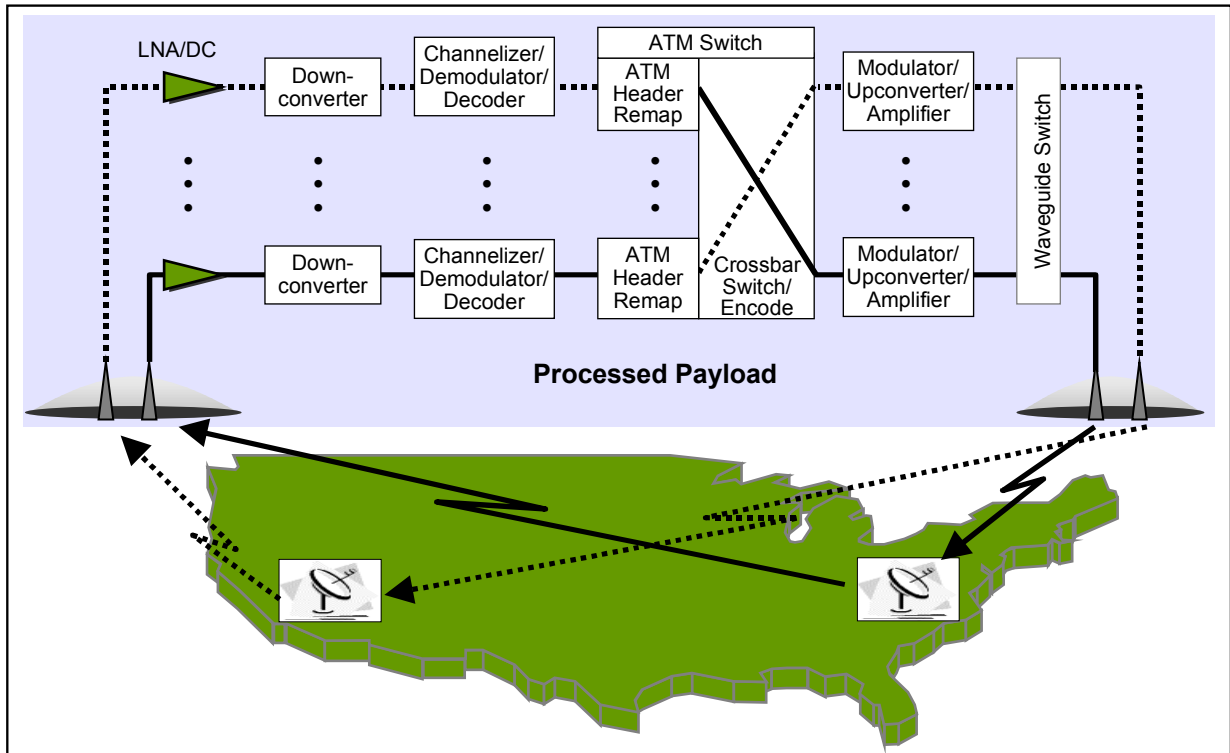

Figure 1. System Block Diagram

01S02418-K-065-154

slots in a time division multiple access (TDMA) structure. FDMA/TDMA was selected over code division multiple access (CDMA) due to lower payload implementation complexity resulting from eliminating overhead associated with processing a separate code for each user, and improved uplink time tracking resulting from lower uplink chip rate. In any of these multiple access schemes, user power control is essential to efficient bandwidth utilization.

- **Low Overhead: Contributing to Bandwidth Efficiency**—Low overhead includes structuring the system to require fewer and shorter burst preambles and synchronization fields. On the other hand, consideration must be made for terminal costs and burst acquisition probability better than $(1 - 10^{-8})$. This requires optimization of the burst preamble lengths and coding of critical information within the frame header.
- **Adaptable Coding**—Sensitivity to rain attenuation dictates an adaptive coding scheme that increases link rain margin at the cost of additional allocated bandwidth. Since forward error correction (FEC) coding increases overhead, adaptive coding adds only as much coding overhead as weather conditions require. A “light code” is applied during transmissions in clear weather. During periods of severe rain attenuation, a “heavy code” can be applied. While some FEC options may provide higher coding gain, the benefits must be balanced against payload implementation costs, such as weight and power.

Some systems employ end-to-end encoding, in which the receive terminal decodes the information encoded by the transmitting terminal. This approach simplifies the payload design by eliminating the need to perform the decoding onboard. There is a significant cost in throughput; however, because the severe rain fade is generally localized over either the transmit terminal or the receive terminal. End-to-end coding forces added coding overhead to be applied to both links.

- **Frame Formats**—The uplink and downlink formats (or forward and return links in a bent-pipe) are logically different because they were selected based on different requirements. Since the downlink is a data stream from a single satellite transmitter to multiple users, longer block lengths with interleaving between multiple encoded data blocks can be used. Also, the burst-to-burst frequency difference due to short-term clock stability on the payload is very small,

thus allowing the burst preambles to be shorter relative to the uplink burst preamble and the received signal-to-noise ratio (SNR). On the other hand, since the uplink is composed of multiple short-duration TDMA bursts from multiple users to a satellite, long block lengths with interleaving between multiple encoded blocks are not feasible. Finally, the synchronization preamble needs to be correspondingly longer to account for the larger burst-to-burst frequency variation between different terminals.

- **Compliance with International Telecommunication Union, Federal Communications Commission, and European Telecommunications Standards Institute Requirements**—Interface specifications must comply with in-band and out-of-band spectral emissions standards to reduce interference with other Ka-Band systems in adjacent orbital slots and frequency bands. This metric drives the modulation pulse shaping and suggests a need for randomization of both uplink and downlink data streams using a data scrambler. Accurate uplink power control is another key to meeting terminal emissions limitations.

- **Fixed Block Lengths**—Whether the basic traffic is internet protocol (IP), frame relay, ATM, or some other protocol, the satellite link physical layer will most likely use a fixed (vs. variable) block size. A fixed block size facilitates bandwidth assignments on a TDMA uplink and also permits a more efficient spaceborne switch architecture, important in maximizing payload throughput while minimizing size, weight, and power.

Uplink burst sizes are an integer multiple of the block size. The block size is a trade between the smallest allocable transmission burst and bandwidth efficiency. Small transmission burst sizes enable optimal allocation of bandwidth to users at the cost of increased synchronization overhead.

- **Quality of Service (QoS)**—There is considerable interest in the ability to guarantee a level of QoS for different classes of service connections since payload power constraints will always result in throughput constriction on the downlink. Research is being done to incorporate QoS in IP networks. In a bursty traffic model, this necessitates large downlink data buffers. Some consideration must be made to segregate high priority and real time traffic from best effort.

- **Flexible Interconnection with Other Terrestrial Networks**—The satellite communications network needs to interconnect with other terrestrial systems, and, consequently, provide for a flexible interface. Most systems consider either ATM or digital video broadcasting (DVB) as the basic protocol since they have the ability to encapsulate other protocols.

The network protocol selected for this paper is based on ATM, which uses a 53-byte fixed-length cell. Various Ka-Band systems—including Astrolink—use the ATM protocol. ATM allows for fixed uplink and downlink block sizes, integrated QoS, and encapsulation of various other protocols. ATM protocol system elements can also be tested using standard commercial test equipment. DVB-S and DVB-RCS provide many of these advantages; however, ATM was selected because it supports a wide variety of traffic types in comparison to DVB-RCS, which is built around an MPEG standard. In addition, DVB is more suited to a bent pipe (versus a processed payload) solution because it employs a concatenated coding scheme built on an inner punctured convolutional code or a turbo code. In a TDMA system with onboard processing, the minimum received signal-to-noise ratio (SNR) is bounded by two factors—the ability of the demodulator to make symbol decisions and the ability of the carrier tracking loop to acquire and track. Since the carrier tracking loop performance is not improved when using powerful convolutional or turbo codes, the additional complexity is not necessary. This paper proposes a coding option that takes into account limited space-based resources with a biorthogonal block code with an option for future implementation of a Nordstrom-Robinson code.

- **Size, Weight, Power, and Cost**—In a satellite-based system, payload size, weight, and power (SWAP) must be carefully traded against terminal cost and antenna size. Small uplink burst rates permit lower terminal effective isotropic radiated power (EIRP), but require finer FDMA spacing that complicates payload channelization. Higher uplink burst rates are also more difficult to synchronize. On the downlink, saturated TWAs in the payload operate at a high DC power efficiency, but require a single carrier per channel, resulting in a higher downlink burst rate for the terminals to process.

UPLINK FRAME FORMAT

The uplink is a burst data stream as shown in Figure 3. A single uplink frame begins with a portion dedicated to timing probes, followed by the data bursts. The timing probes are short sync pulses transmitted by each terminal in its assigned FDMA/TDMA slot. Terminals use this burst to maintain fine timing with the spacecraft onboard symbol clock based on early/late responses from the payload. An additional channel may optionally be allocated as an Entry Probe channel to permit coarse timing acquisition for terminals initially entering the system.

As shown in Figure 2, the uplink terminal groups four ATM cells into a block. An acquisition sequence is prepended to each block to permit the onboard demodulator to acquire phase and frequency. The terminal then Reed-Solomon encodes, scrambles (for energy dispersal), optionally biorthogonal encodes and demultiplexes the block into in-phase and quadriphase components, and the demultiplexed data streams are quadrature phase shift keyed (QPSK)-modulated.

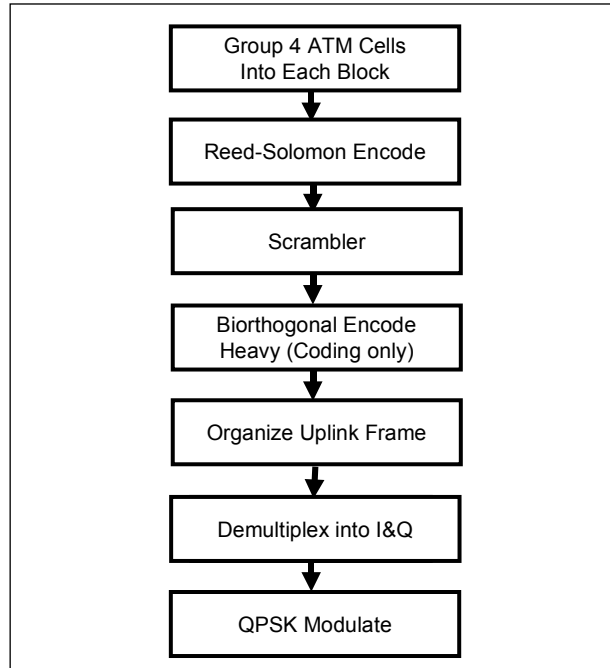

01S02418-K-024-154

Figure 2. Uplink Frame Synthesis

The uplink frame provides a balance between maximum efficiency and minimum overhead (Figure 3). For example, the 4-cell uplink block size was selected to balance bandwidth efficiency and synchronization overhead. Small block sizes permit minimum bandwidth allocation quantization of approximately 16 kbps while keeping the overhead for the synchronization preamble at about 2 percent of the uplink frame.

The time probe and entry probe fields are designed for efficient and accurate time acquisition and tracking. It is important to maintain time tracking accuracy to less than 5 percent of a symbol time. This allows the demodulator to process all channels in parallel using the same symbol clock. This constraint significantly reduces the demodulator complexity, weight, and power consumption. It also minimizes the required guard slots between consecutive uplink bursts, further reducing the overhead.

DOWNLINK FRAME FORMAT

The downlink is a continuous datastream. The downlink groups four ATM cells into a block (Figure 4), Reed-Solomon encodes the block, and byte-interleaves multiple blocks (shown later in Figures 7 and 8). The demultiplexed data streams are then scrambled for energy dispersal, separately convolutionally-encoded, and QPSK-modulated.

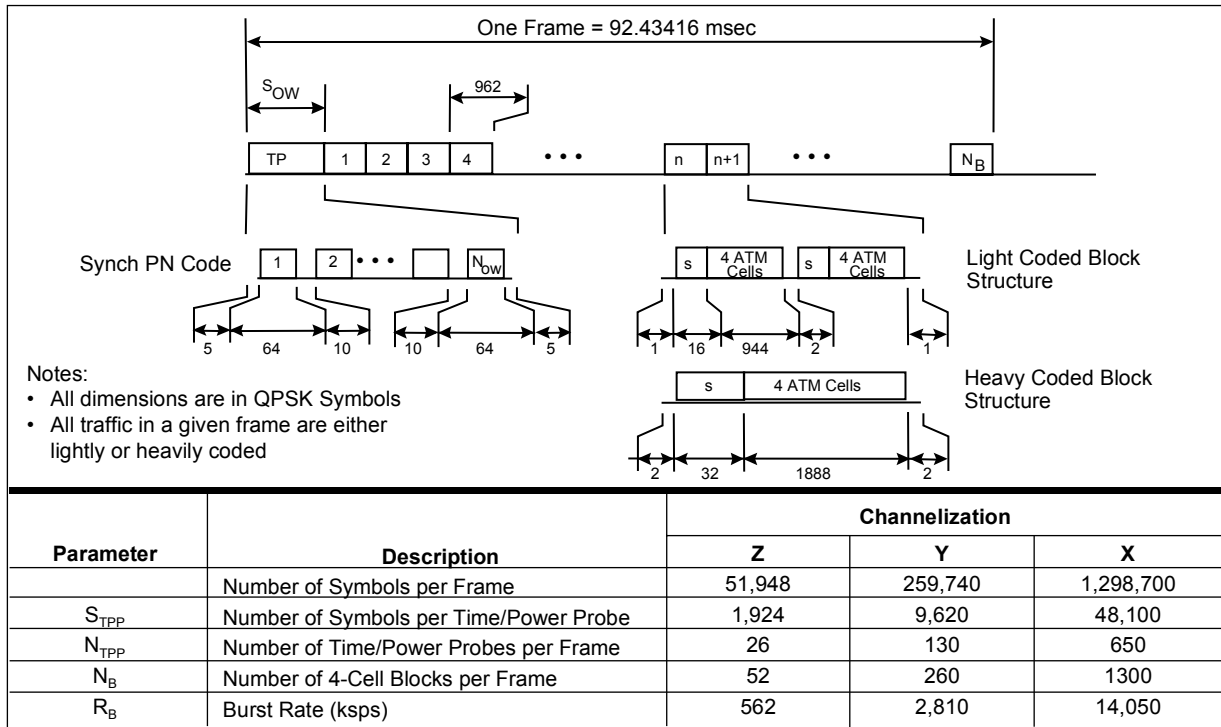

Figure 3. Uplink Frame Format

01S02418-K-025-154

The downlink transmission is single carrier, so that the transmit chain can operate in its most efficient fully saturated mode. In addition, the downlink waveform is designed to enable time-sharing of a single downlink carrier among multiple beam locations via beam-hopping.

Similar to the uplink frame, the downlink frame is constructed to balance efficiency and robustness (Figure 5). Since the satellite-to-ground link is a transmission from a single satellite to multiple users, a longer frame length is used. The frame preamble is optimized for higher downlink channel rate and split between the start and middle of the frame to support beam hopping. The frame-type field identifies the data burst code rate and is heavily coded to prevent loss of an entire data block.

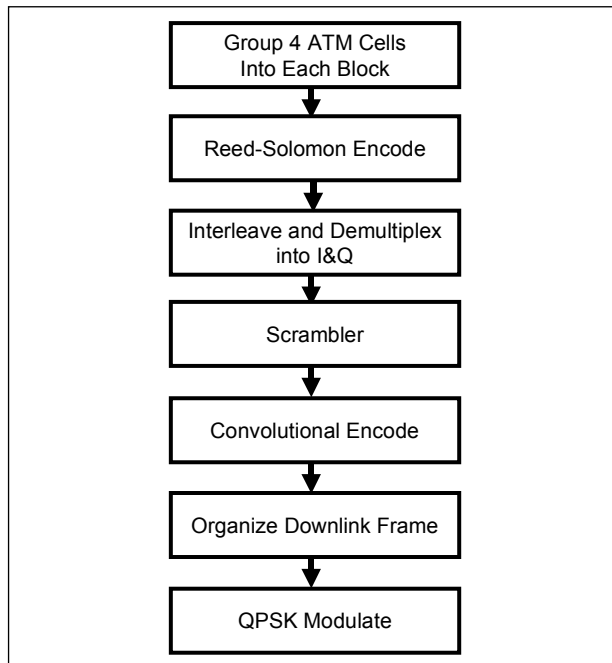

Figure 4. Downlink Frame Synthesis

01S02418-K-027-154

The proposed interface also incorporates the concept of a master frame and consists of eight uplink or 9323 downlink frames. Since the master frame is an integral number of both uplink and downlink frames, it is useful for defining the uplink-to-downlink timing relationships needed for terminals to determine correct uplink frame timing. In addition, the master frame concept allows the possibility of assigning TDMA uplink resources to terminals on either an uplink frame or master frame cycle.

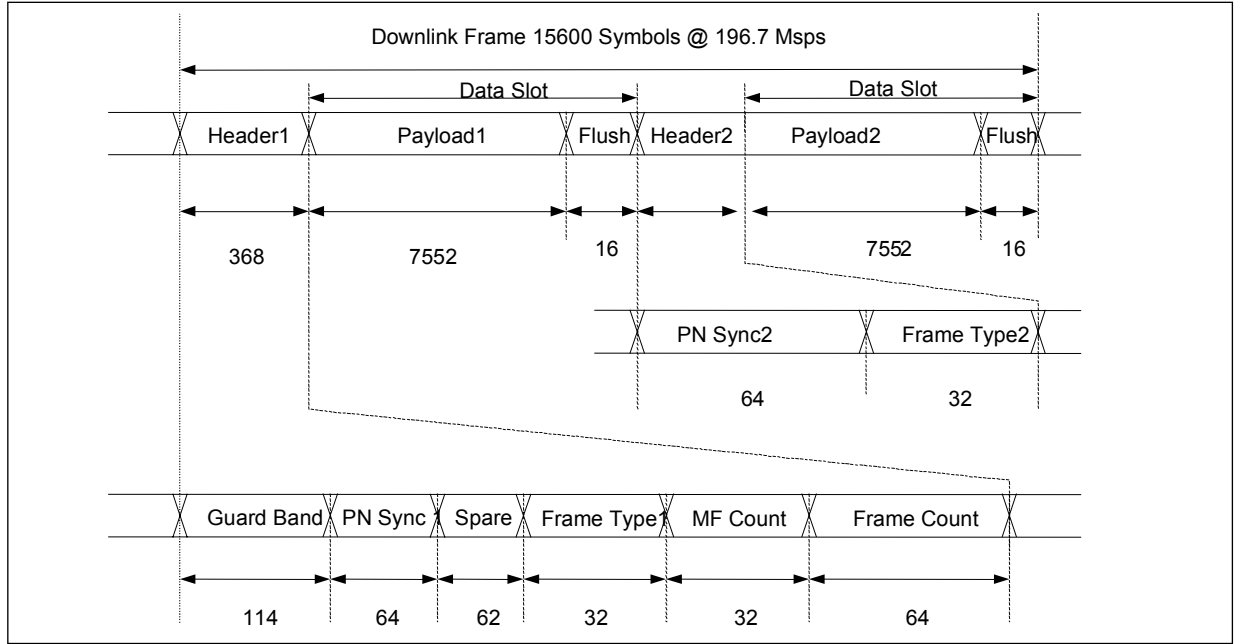

Figure 5. Downlink Frame Format

01S02418-K-028-154

UPLINK AND DOWNLINK MODULATION

The modulation needs to balance spectral efficiency versus bit error rate at reasonable SNR. It should also employ pulse shaping to minimize adjacent channel interference (ACI) and intersymbol interference (ISI). The proposed interface employs QPSK with square-root raised cosine (SRRC) pulse shaping. The SRRC excess bandwidth, $\alpha = 0.25$, was selected to minimize ACI on the uplink and to balance ACI and ISI on the downlink. This combination also performs well in the presence of timing and frequency errors.

$$p(t) = \frac{1}{2\pi} \int_{-\infty}^{\infty} P(f) e^{-j2\pi ft} df \quad (1)$$

where

$$P(f) = \begin{cases} \sqrt{T_{sym}}, & |f| \leq \frac{1-\alpha}{2T_{sym}}, \\ \sqrt{\frac{T_{sym}}{2}} \left\{ 1 - \sin \left[\frac{T_{sym}\pi}{\alpha} \left| |f| - \frac{1}{2T_{sym}} \right| \right] \right\}, & \frac{1-\alpha}{2T_{sym}} < |f| \leq \frac{1+\alpha}{2T_{sym}}, \\ 0, & |f| > \frac{1+\alpha}{2T_{sym}}. \end{cases}$$

UPLINK CODING

The uplink code is a Reed-Solomon $(n, k, d) = (236, 212, 25)$ 12-error correcting outer code concatenated with either a biorthogonal or a punctured Nordstrom-Robinson inner code. Because the probability of an undetected Reed-Solomon decoding error is very low, the code provides a robust mechanism for the payload to detect whether a burst was transmitted. This is significant in a TDMA system where terminals may not transmit in every assigned time slot. This combination also provides good performance with low computational complexity—an important consideration in the uplink due to the payload SWAP constraints. More powerful codes such as convolutional or turbo codes are significantly more complex to decode.

Similar to the downlink, the basic unit of uplink information is a block of four 53-byte ATM cells for a total of 212 8-bit bytes. This 212-byte block is Reed-Solomon encoded to form a block of 236 8-bit bytes. Each 8-bit byte is either encoded into two $(n, k, d) = (8, 4, 4)$

biorthogonal codewords or one $(n, k, d) = (16, 8, 6)$ extended Nordstrom-Robinson codeword. The Nordstrom-Robinson code is straightforward to decode using a reduced-complexity, soft-decision decoding algorithm. The E_c/N_0 corresponding to a CLR of 3×10^{-8} vs. inner code is shown in Figure 6.

DOWNLINK CODING

The downlink code is a Reed-Solomon $(n, k, d) = (236, 212, 25)$ 12-error correcting outer code concatenated with a rate- $m/8$ constraint-length-7 convolutional code. The value of m can vary between 1 and 8 (in which case, there is no inner coding) to achieve different coding gains. Similar to the uplink, the basic unit of downlink information is a block of four 53-byte ATM cells for a total of 212 8-bit bytes. This 212-byte block is Reed-Solomon encoded to form a 236-byte block. Since the inner code is a convolutional code, decoding failures result in a burst of bit errors. As a consequence, byte interleaving to depth- m between multiple outer codewords and the inner code spreads the burst errors among multiple Reed-Solomon codewords. Examples of this interleaving for $m = 3$ and $m = 6$ corresponding to rate- $3/8$ and rate- $6/8$ convolutional codes are shown in Figures 7 and 8.

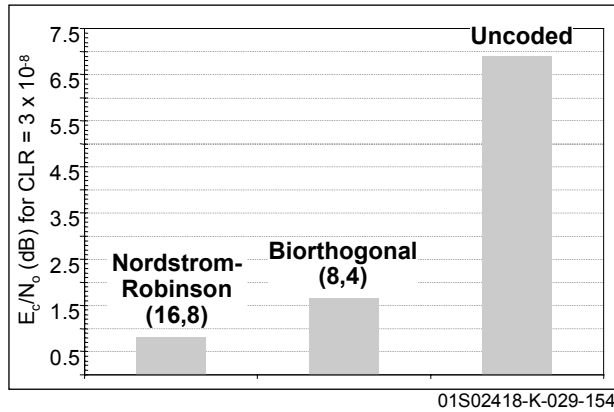

Figure 6. E_c/N_0 for a CLR of 3×10^{-8} vs. Inner Code

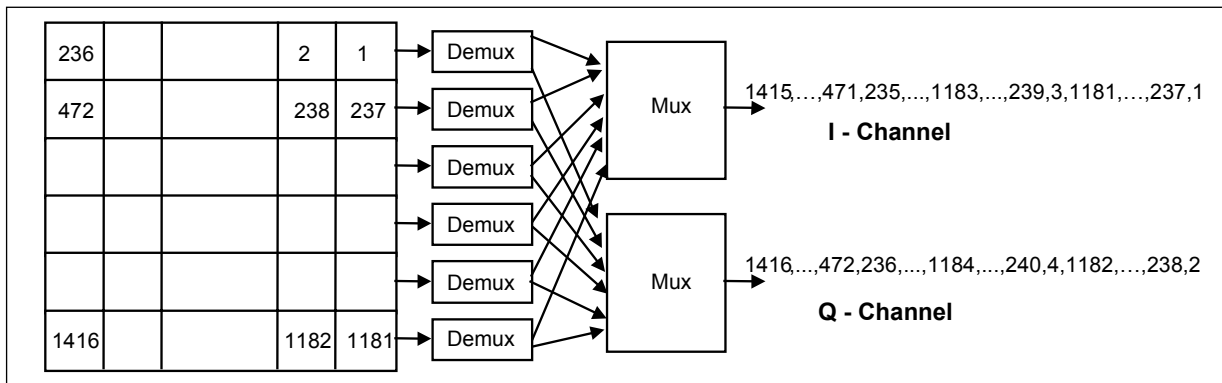

Figure 7. Block Interleaving with a Rate-6/8 Inner Code

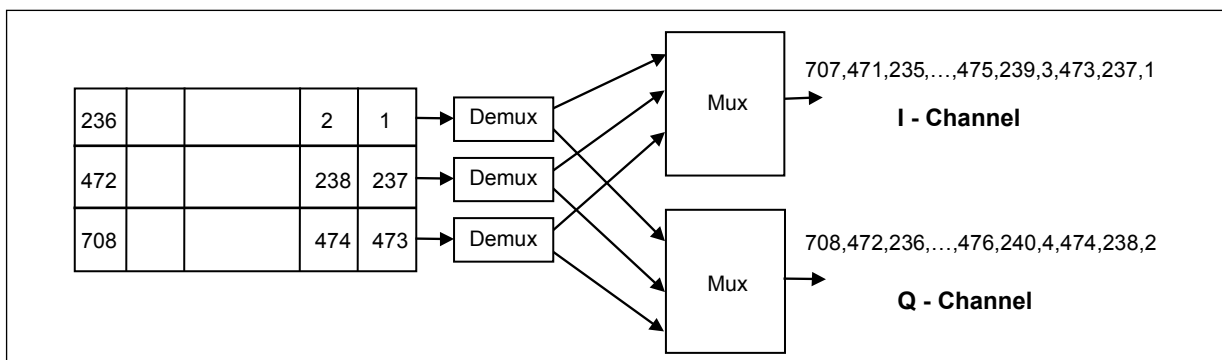
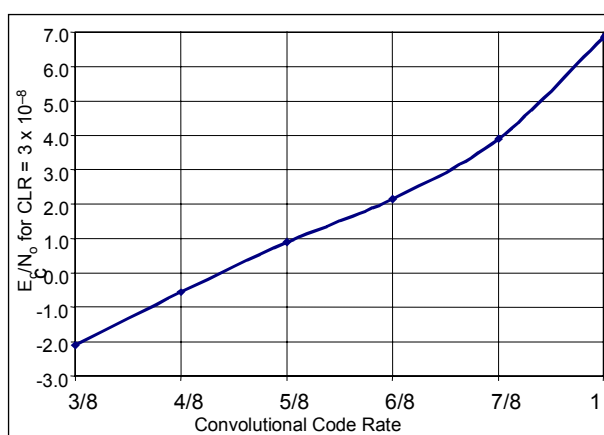

Figure 8. Block Interleaving with a Rate-3/8 Inner Code

The number of Reed-Solomon words, hence the interleaving depth, is selected to be m , so the total concatenated block size is constant; i.e., $236 \times 8 \times m$ inner coded bits result in $236 \times 8 \times m \times 8/m = 15,104$ channel bits. As a result, the data rate and block size on the air interface is constant, and the user ATM cell rate changes to accommodate adaptive coding.

DOWNLINK CODING PERFORMANCE

As a result of the coding structure, the Reed-Solomon (236, 212) decoder virtually never makes undetected decoding errors: a codeword is either decoded correctly or the decoder flags a decoding failure, in which case the codeword is usually discarded. Since codewords with errors are discarded, the cell error rate (CER) is essentially zero, and a more appropriate measure of performance is cell loss ratio (CLR), which corresponds to Reed-Solomon decoder block error rate. The E_c/N_o corresponding to a CLR of 3×10^{-8} vs. convolutional code rate is shown in Figure 9. E_c is the energy per channel bit. Performance is normalized to E_c/N_o rather than the more conventional E_b/N_o since the channel data rate is constant, and E_c/N_o directly relates to link margin (and hence propagation loss). These six coding options provide a menu of selectable performance.



01S02418-K-033-154

Figure 9. E_c/N_o for a CLR of 3×10^{-8} vs. Convolutional Code Rate

SUMMARY

We have designed a generalized interface between space and ground terminals. The waveform has many features that enable excellent performance in broadband satellite systems. Figure 10 highlights the features of the waveform that apply to each of the metrics identified earlier in this paper.

While the waveform defined here was developed for Ka-Band space links, the features of the waveform provide similar benefits for wideband systems at other frequencies such as C-Band, Ku-Band and V-Band.

Metric	Waveform Feature
Bandwidth Efficiency	<ul style="list-style-type: none"> • FDMA/TDMA/DAMA uplink access scheme • Multiple uplink channel rates • Small 4-ATM-cell uplink burst size • Single carrier saturated downlink • Low interference SRRC pulse shaping • Closed loop uplink power control
Low Overhead	<ul style="list-style-type: none"> • Robust coding for essential frame fields • High burst acquisition probability due to efficient synchronization scheme
Adaptable Coding	<ul style="list-style-type: none"> • Powerful concatenated code for uplink and downlink • Flexible inner code enables adaptability to atmospheric environment • Interleaving on downlink to spread decode failures from inner convolutional code
Frame Formats	<ul style="list-style-type: none"> • Robust coding for essential fields • Short transmission blocks on uplink; longer blocks on downlink
Compliance with ITU, FCC, and ETSI Requirements	<ul style="list-style-type: none"> • SRRC pulse shaping, $\alpha=0.25$ • Scrambling of both uplink and downlink data streams • Robust uplink power control metrics: satellite received power and satellite received SNR
Fixed Block Lengths	<ul style="list-style-type: none"> • Uplink: 4-cell transmission block • Downlink: single cell transmission within 12 or 24 cell block
Flexible Interconnection with Other Terrestrial Networks	<ul style="list-style-type: none"> • ATM protocol • Proven encapsulation of other terrestrial standards
Quality of Service	<ul style="list-style-type: none"> • ATM protocol • Low cell loss rates
Size, Weight, Power, and Cost	<ul style="list-style-type: none"> • Saturated downlink channel shared by multiple beam locations • Low complexity encoding and decoding • 4-cell uplink bursts • Commercial standard ATM protocol enables low cost test equipment

Figure 10. Waveform Features