

X=3100  $\mu$ m Y=1200  $\mu$ m

**Features**

- ◆ X2 Active Multiplier
- ◆ Input frequency: 46 to 48 GHz
- ◆ Output frequency: 92 to 96 GHz
- ◆ Conversion Gain: 3 dB (typ.)
- ◆ Conversion Gain @ ~Pinchoff: 5 dB (typ.)
- ◆ RF Input Power: -5 dB (typ.)
- ◆ Die Size: < 3.8 sq. mm

**Applications**

- ◆ Short Haul / High Capacity Links
- ◆ Sensors
- ◆ Radar

**Product Description**

The XDH150 is a monolithic HEMT multiplier designed for use in commercial digital radios and wireless LANs. To ensure rugged and reliable operation, HEMT devices are fully passivated. Both bond pad and backside metallization are Ti/Au, which is compatible with conventional die attach, thermocompression, and thermosonic wire bonding assembly techniques.

**Performance Characteristics (T<sub>OP</sub> = 25°C)**

Specification	Min	Typ	Max	Unit
Input Frequency	46		48	GHz
Output Frequency	92		96	GHz
Input Power		-5		dBm
Output Power	-4	-2		dBm
Conversion Gain	1	3		dB
Vd1		4		V
Id1		80		mA
Vd2		4		V
Id2		20		mA
Vg1		0		V
Vg2		-0.1		V
Conversion Gain @ ~Pinchoff		5		dB
Id2 @ ~Pinchoff		0.5		mA

**Absolute Maximum Ratings (T<sub>OP</sub> = 25°C)**

Parameter	Min	Max	Unit
Vd1		5.5	V
Id1		90	mA
Vd2		5.5	V
Id2		20	mA
Vg1	-1	+0.3	V
Vg2	-1	+0.3	V
Input Drive Level		0	dBm
Assy. Temperature (60 seconds)		300	°C

Note: The data contained in this document is for information only. Northrop Grumman reserves the right to change without notice the specifications, designs, prices or conditions of sale, as they apply to this product. The product represented by this datasheet is subject to U.S. Export Law as contained in the ITAR. **This product is for U.S. Sales only. Export out of the U.S. requires a U.S. State Department export license.**



**On-Wafer Measured Performance Characteristics ( $T_{OP} = 25^{\circ}C$ )**  
 **$P_{in} = -5$  dBm,  $V_d = 4V$ ,  $I_{d1} = 80$  mA,  $I_{d2} = 20$  mA (Screen Specification Conditions)**

**Conversion Gain**

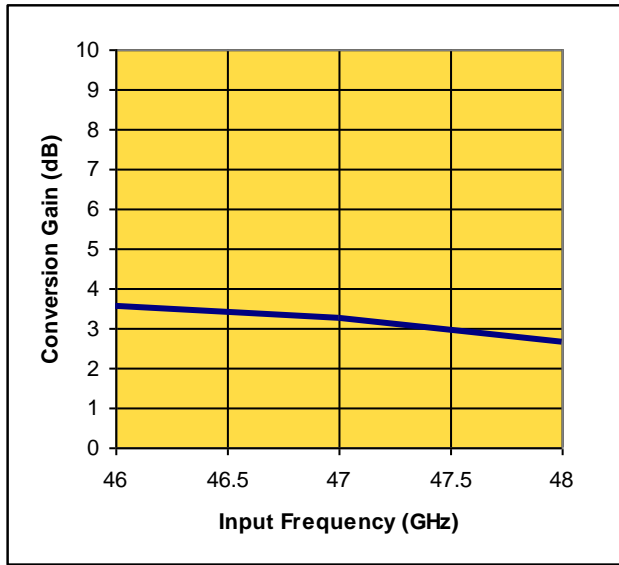

**Output Power**

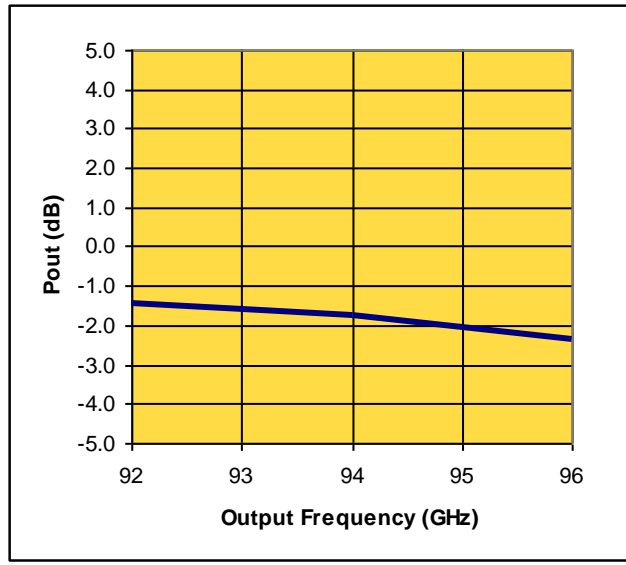

**On-Wafer Measured Performance Characteristics ( $T_{OP} = 25^{\circ}C$ )**  
 **$P_{in} = -5$  dBm,  $V_d = 4V$ ,  $I_{d1} = 80$  mA,  $I_{d2} = 0.5$  mA**

**Conversion Gain**

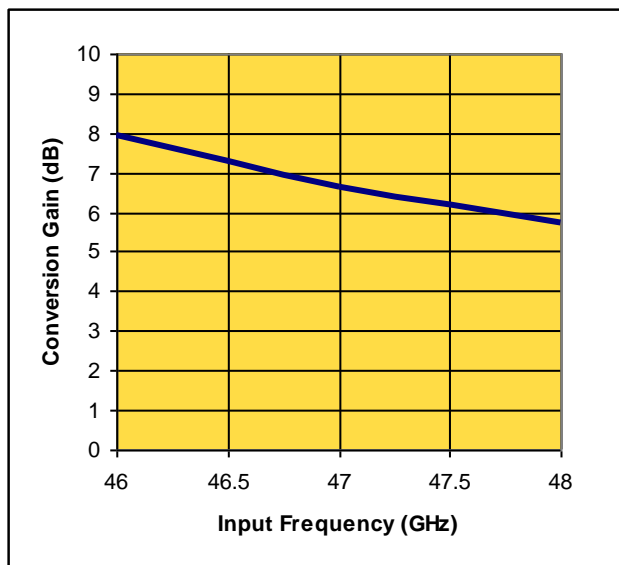

**Output Power**

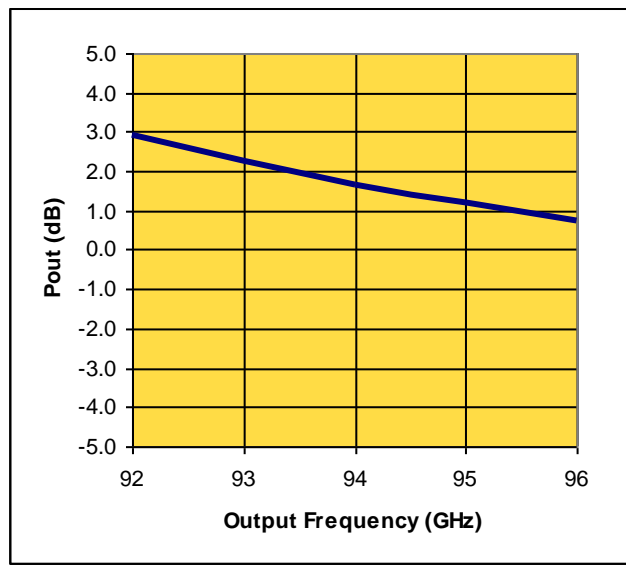

Note: The data contained in this document is for information only. Northrop Grumman reserves the right to change without notice the specifications, designs, prices or conditions of sale, as they apply to this product. The product represented by this datasheet is subject to U.S. Export Law as contained in the ITAR. **This product is for U.S. Sales only. Export out of the U.S. requires a U.S. State Department export license.**

**Die Size and Bond Pad Locations**

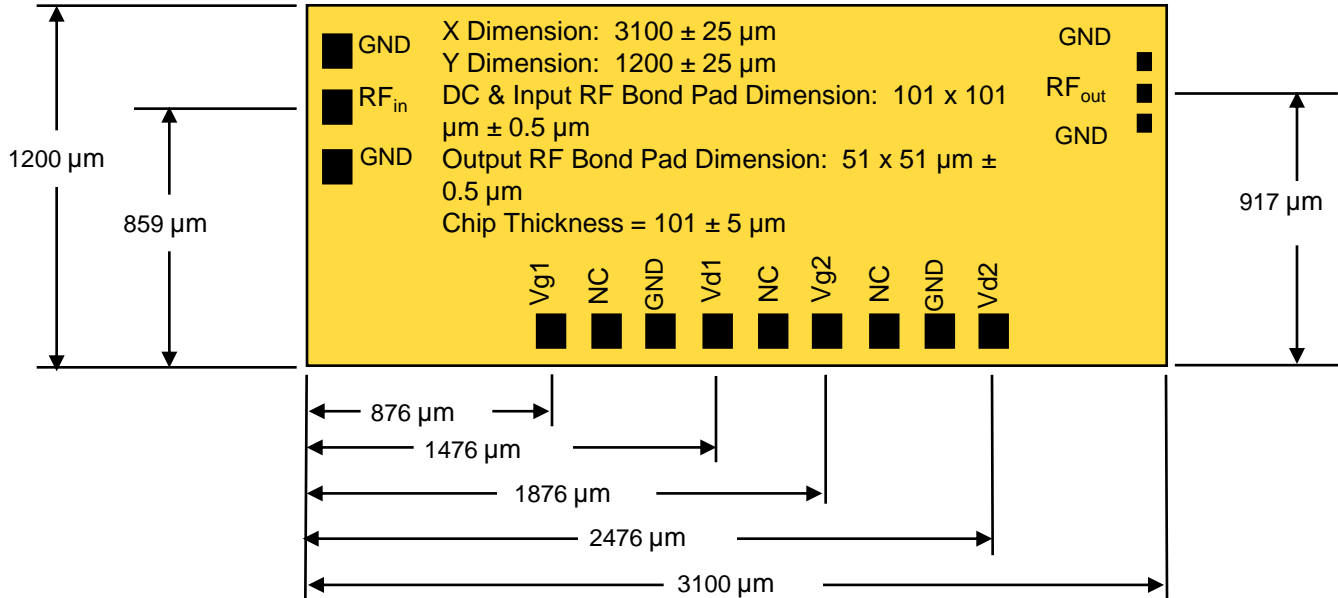

**Application Circuit**

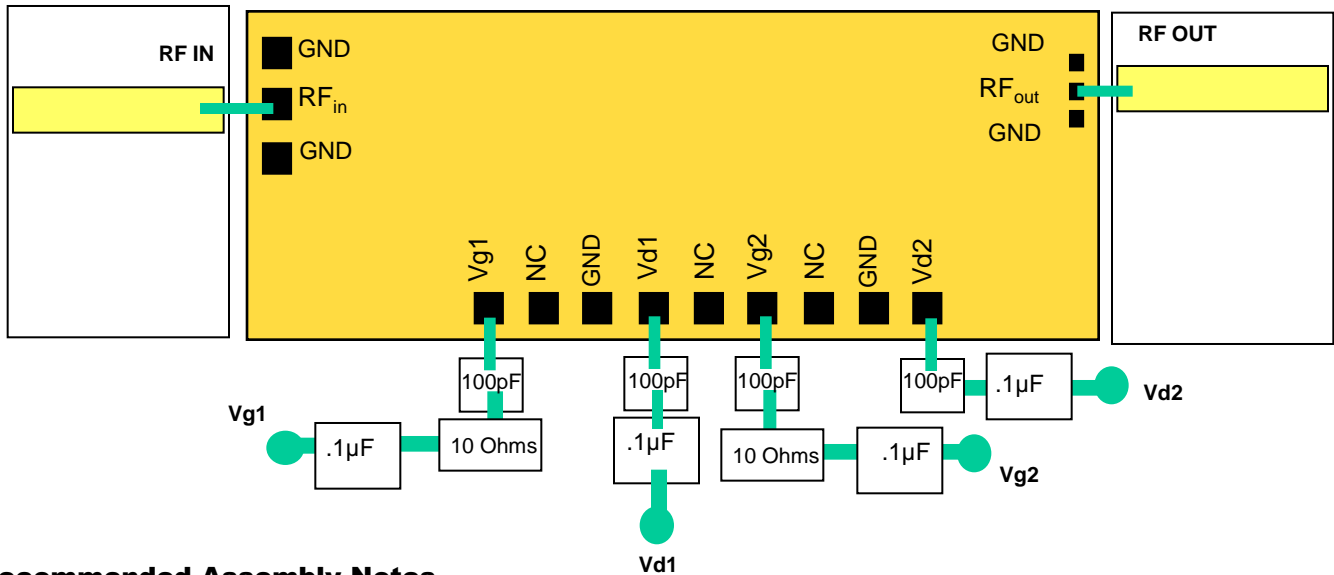

**Recommended Assembly Notes**

1. Bypass caps should be 100 pF (approximately) ceramic (single-layer) placed no farther than 30 mils from the amplifier.
2. Input bond pad & dc bias pads dimensions are 0.1mm x 0.1mm (4mil x 4mil).
3. Output bond pad dimension is 0.05mm x 0.05mm (2mil x 2mil).
4. Best performance obtained from use of <10 mil (long) by 3 by 0.5 mil ribbon on input bond pads and <6 mil (long) by 1.5 by 0.5 mil ribbon on output bond pads

Note: The data contained in this document is for information only. Northrop Grumman reserves the right to change without notice the specifications, designs, prices or conditions of sale, as they apply to this product. The product represented by this datasheet is subject to U.S. Export Law as contained in the ITAR. **This product is for U.S. Sales only. Export out of the U.S. requires a U.S. State Department export license.**