

# **Highly Linear and Compact MMW Phased Array Transmitters**

**November 11, 2003**

R. Lai, M. Siddiqui, B. Pitman, M. Nishimoto, K. Johnson, S. Din, O. Fordham, G. Schreyer, R. Grundbacher, L. Callejo and D. Streit,  
*Northrop Grumman Space Technology, Redondo Beach, CA 90278*

# Critical Technology that will Enable Next Generation Satcom Phased Arrays

- Next generation phased array designs will be driven by desire for increased capacity
- Evolution to smaller beam widths and more simultaneous beams favors phased arrays
  - ~100 simultaneous beams from one aperture
  - Today's typical communication links use complex modulation requiring greater than 26 to 30 dB C/N for BER of  $10^{-6}$  to  $10^{-9}$
- Critical phased array technologies will be:
- High efficiency and linearity SSPA's
  - Maintain high C/I with many beams
  - $P_{1dB}$  is not a good measure of linearity for multi-carrier modulation
  - Two tone  $OIM_3 / OIP_3$  is an approximation for multi-carrier schemes
  - Noise to Power Ratio (NPR) for intra channel signal distortion
  - Adjacent Channel Power Ratio (ACPR) for adjacent channel interference
- Compact multiple-beam beam formers
  - Earth coverage, ~1000 beams
  - Need to reduce die size and cost

Phased Array

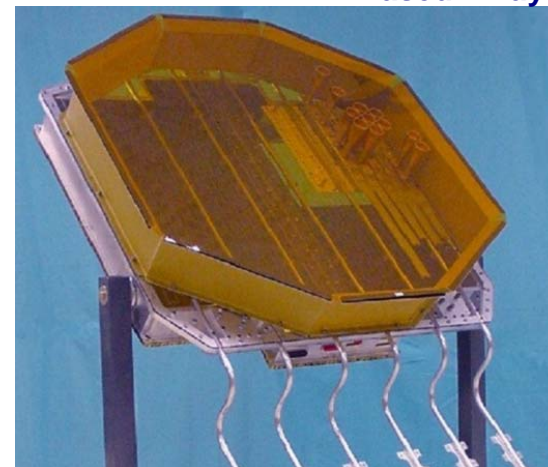

0.7 deg beams

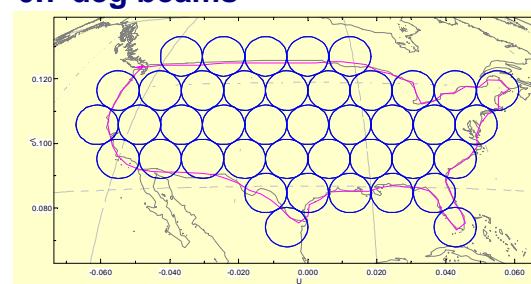

0.4 deg beams

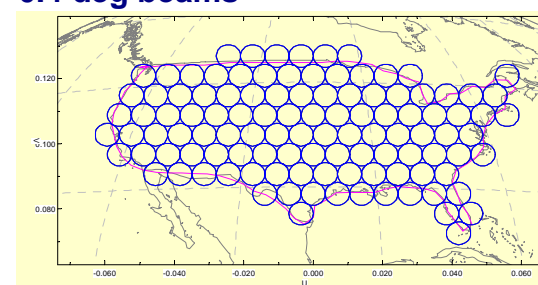

# Background

## Noise Power Ratio Explained

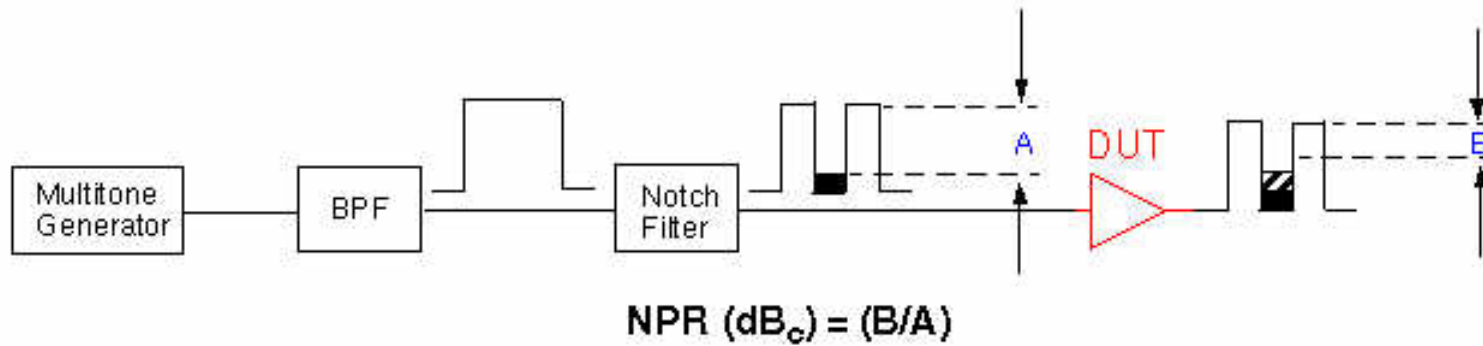

## Adjacent Channel Power Ratio Explained

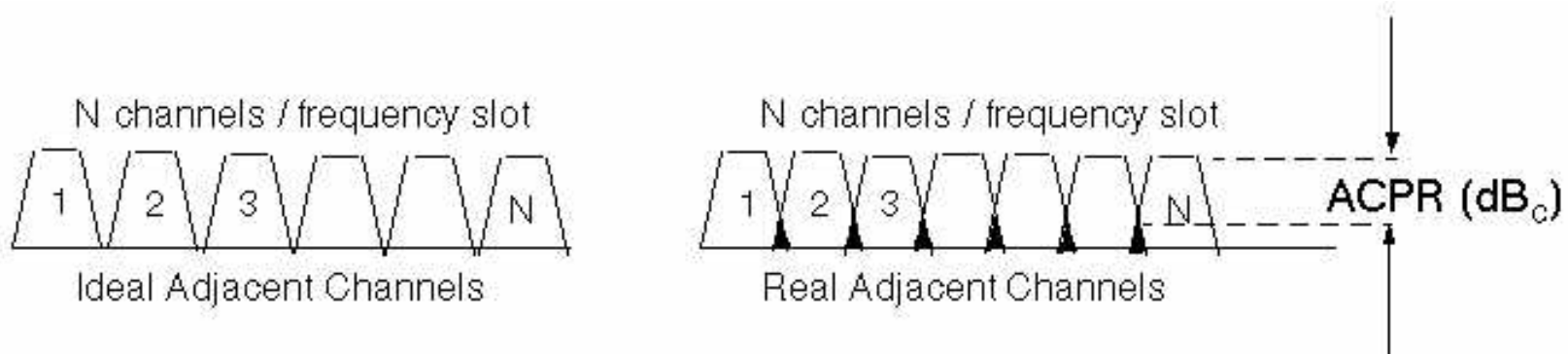

# Outline

- Selected linearity tests were performed at different frequencies dependent on test equipment availability.
- A sampling of measurements at frequencies from 20 GHz to 46 GHz are presented.
- All 1 watt amplifiers have similar topologies:
  - Show similar  $P_{1dB}$ ,  $P_{sat}$  and  $OIP_3$  behavior.
  - ACPR and NPR behavior should be similar.
  - Behavior over temperature is similar.

# NGST 0.15 $\mu$ m GaAs PHEMT

- Flight qualified profile (die thickness: 100  $\mu$ m; 50  $\mu$ m.)
- $F_T \sim 75$  to 80 GHz @  $V_{DS} = 5V$
- $I_{max} \geq 600$  mA/mm
- $V_{BD} > 9$  V @ 0.1 mA/mm,  $> 11V$  @ 1 mA/mm
- $G_m > 550$  to 600 mS/mm
- $OIP_3 \geq P_{1dB} + 9dB$  or better @ 10dB OBO
  - $OIP_3 \geq P_{1dB} + 9dB$  holds at 5dB OBO
- $P_{1dB} \sim 400$  to 500 mW/mm;  $P_{sat} \sim 500$  to 650 mW/mm

# 20 GHz Driver Amplifier

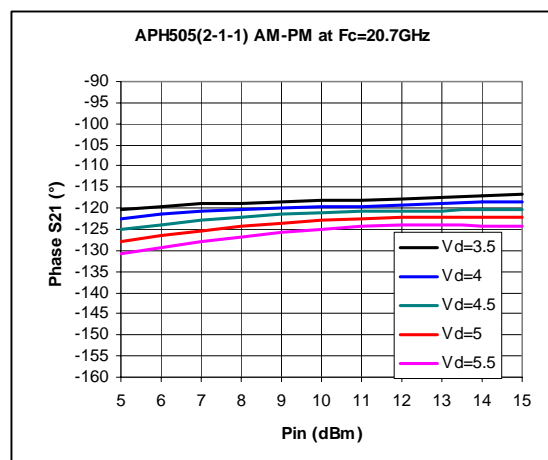
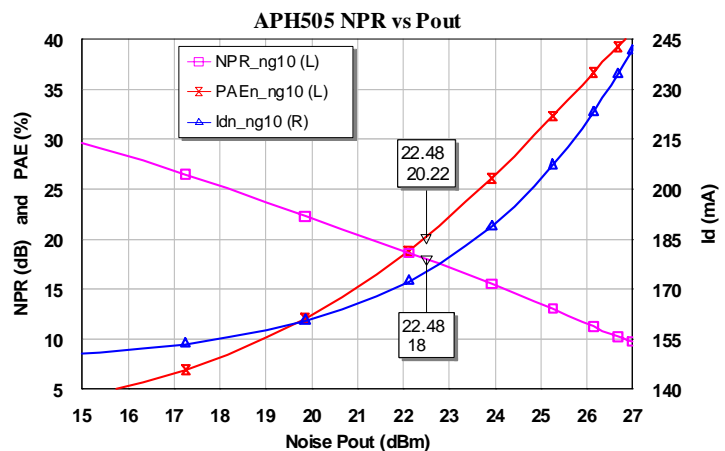
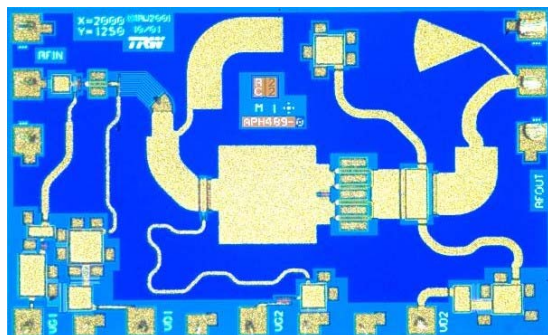

- Freq: 20 GHz
- Gain: 20 dB
- $P_{1dB}$ : 25 dBm (329 mW/mm, 30% PAE)
- $P_{sat}$ : 26 dBm (414 mW/mm, > 42% PAE)
- $OIP_3$ : 35 dBm ( $IM_3 = -46dB_c @ 10dB OBO$ )
- AM/PM  $\leq 5$  degrees under drive
- NPR calculated > 18dB<sub>c</sub> @ 4.5 OBO
  - Using single tone AM/PM,  $P_{in}/P_{out}$  and current vs. drive characteristics.
- PAE at NPR > 18dB<sub>c</sub> ~ 21%
- Size: 2.5 mm<sup>2</sup>

**State-of-the-art NPR for multi beam operation**

# 24-26 GHz Power Amplifier

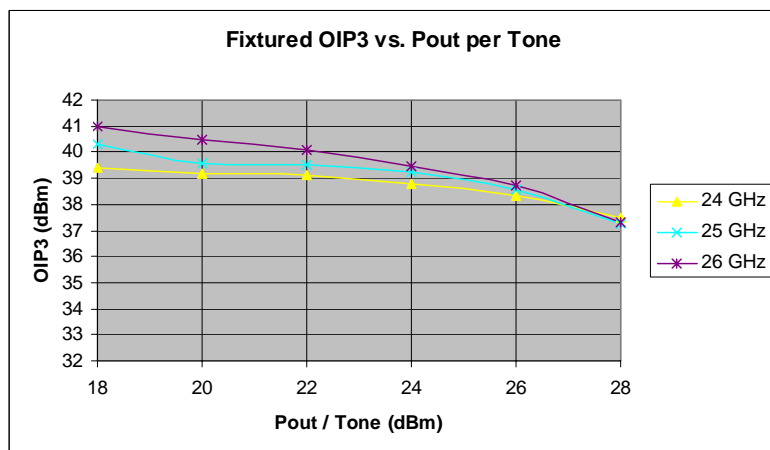
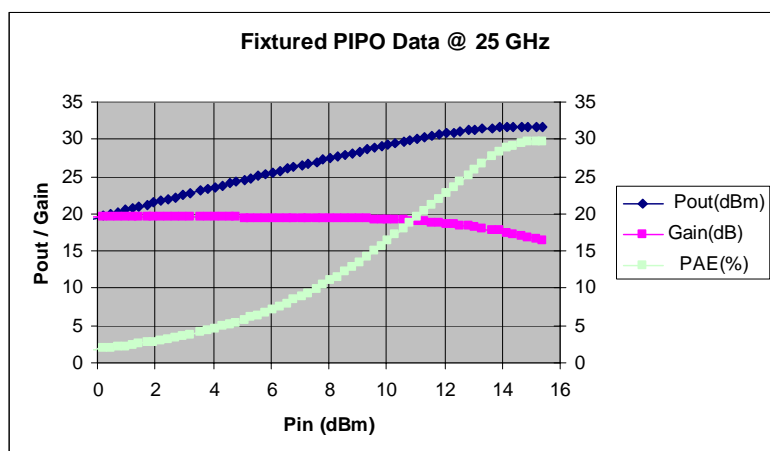
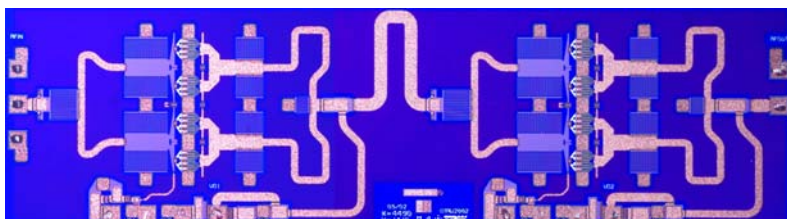

- Freq: 24 to 26 GHz
- Gain: 18 dB
- $P_{1dB}$ : 31 dBm (525 mW/mm, 22% PAE)
- $P_{sat}$ : 32 dBm (660 mW/mm, 29% PAE)
- $OIP_3$ : 40.5 dBm ( $IM_3 = -45dB_c$  @ 10dB OBO)
- Size: 5.88 mm<sup>2</sup>
- Amplifier topology chosen for maximum linear performance. PAE was a secondary consideration.

**At  $P_{out} = (P_{1dB} - 2 dB)$ ,  
 $IM_3 = -25 dB_c$  !**

# ACPR Test Bench

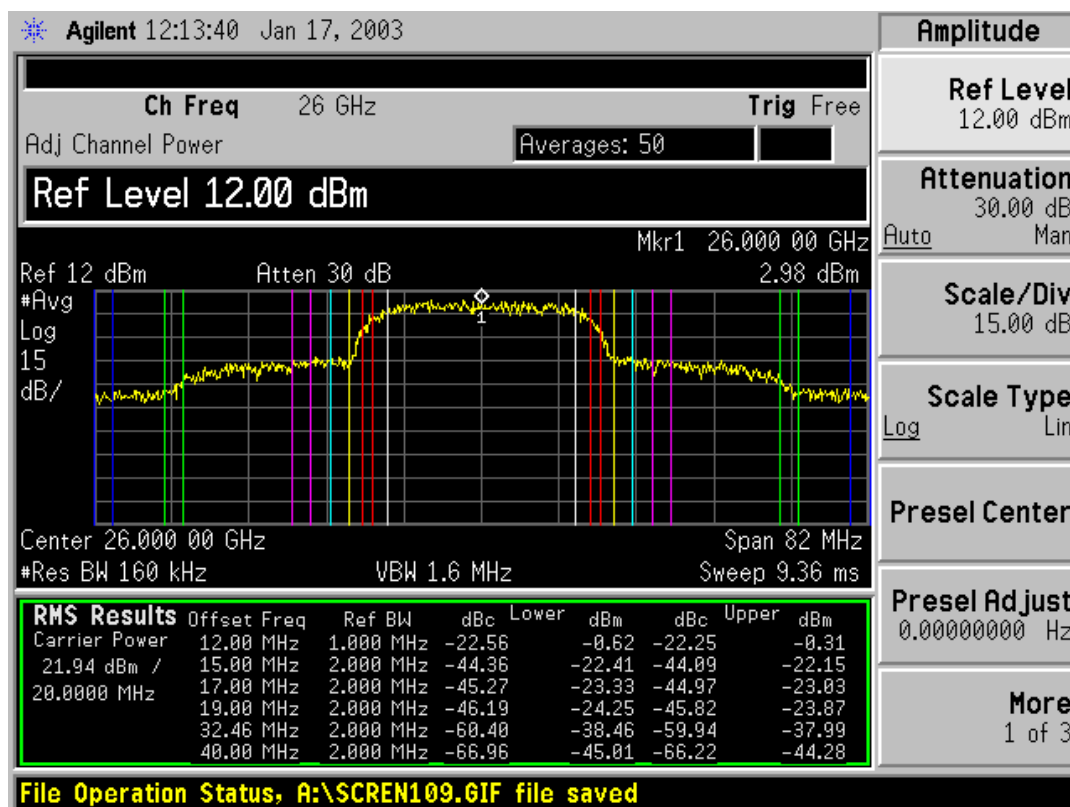
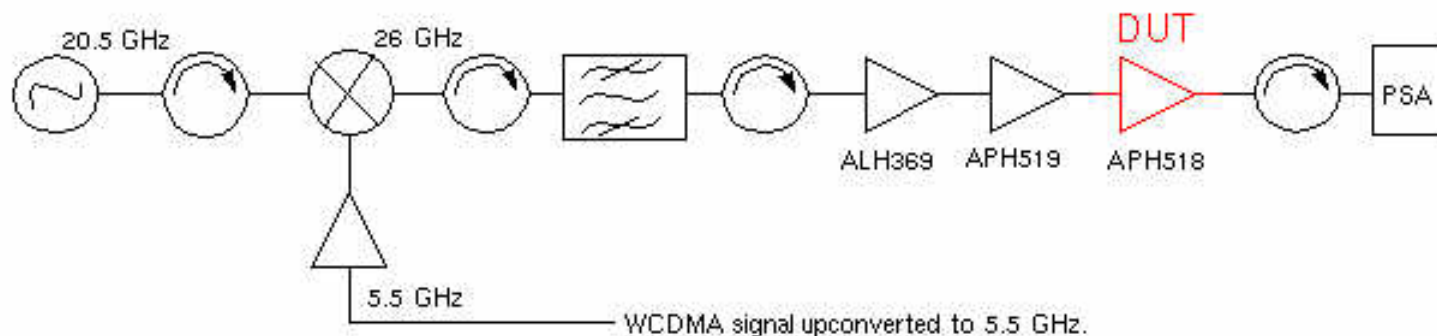

- Freq: 26 GHz
- WCDMA (25MHz BW) up converted to pass band.
- **ACPR > -44dBc @ 5 MHz offset**
- Raw test data (no corrections for test set)
- Performance is expected to repeat for power amplifiers up to 45 GHz processed in NGST's 0.15um 4mil GaAs .

**Excellent linearity (ACPR) @**

$$P_{out} = P_{1dB} - 9dB$$

# 37-40 GHz Power Amplifier

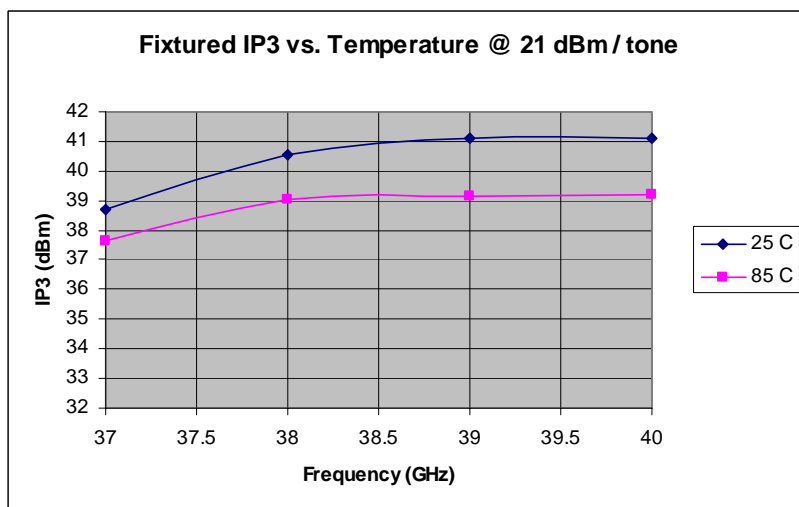
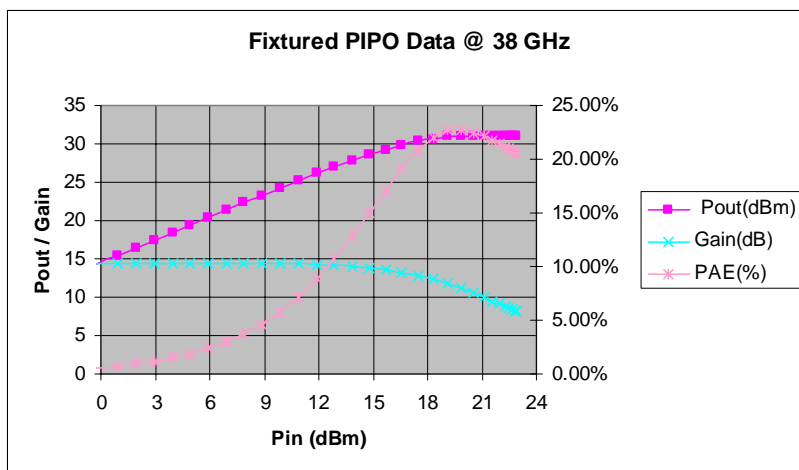
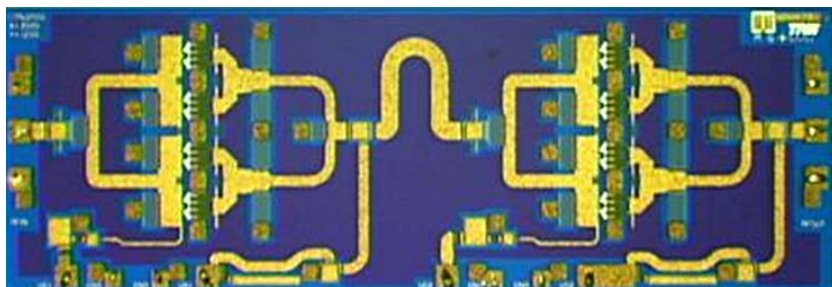

- Freq: 37 to 40 GHz
- Gain: 15 dB
- $P_{1dB}$ : 30 dBm (463 mW/mm, 18% PAE)
- $P_{sat}$ : 31 dBm (583 mW/mm, 20% PAE)
- $OIP_3$ : 41 dBm ( $IM_3 = -40dB_c$  @ 6dB OBO)
- $OIP_3$  degrades 2 dB at 85 degrees C.
  - $OIP_3$  very well behaved over temperature.
- Size: 4.5 mm<sup>2</sup>
- Temperature performance typical of all NGST linear power amplifiers.

**$IM_3 = -36 dB_c$  @ 85 degrees C with 6dB OBO !**

# 40-44 GHz Power Amplifier

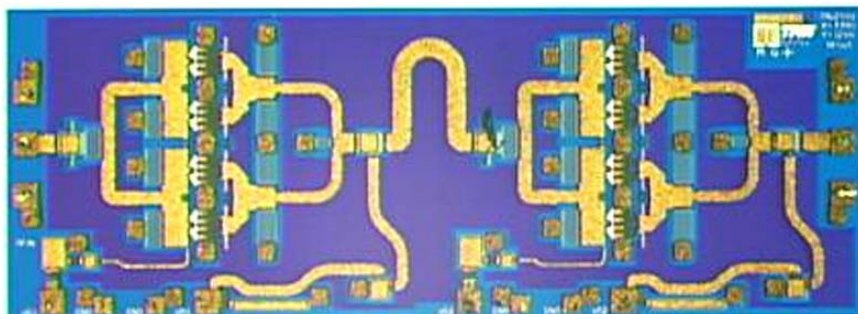

- Freq: 40 to 44 GHz
- Gain: 12 dB
- $P_{1dB}$ : 29 dBm (368 mW/mm, 14% PAE)
- $P_{sat}$ : 30 dBm (463 mW/mm, 18% PAE)
- $OIP_3$ : 39 dBm ( $IM_3 = -42dB_c @ 8dB OBO$ )
- Size: 4.25 mm<sup>2</sup>

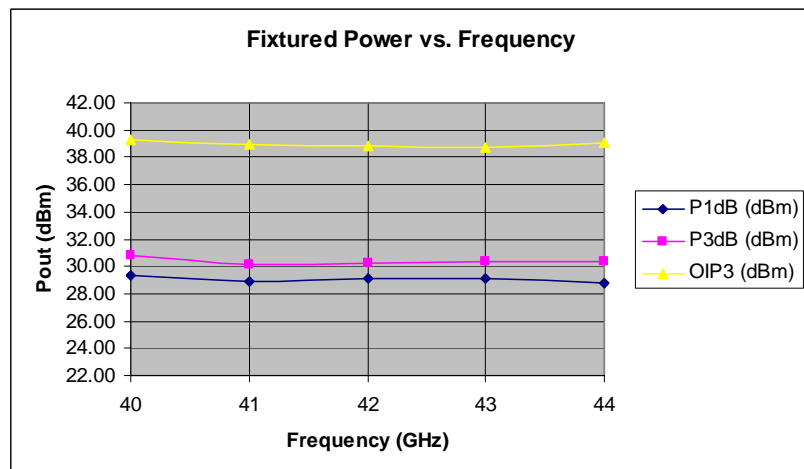
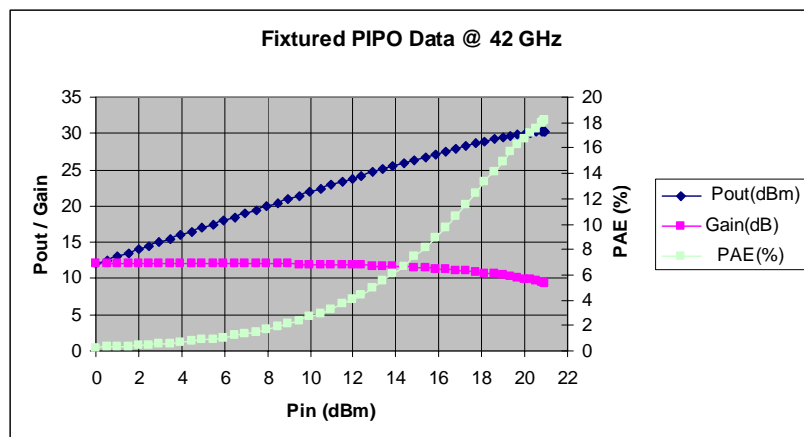

**$OIP_3 = P_{1dB} + 10dB$  with gain of only 6dB per stage!**

# 43-47 GHz Phased Array Transmit Amplifier

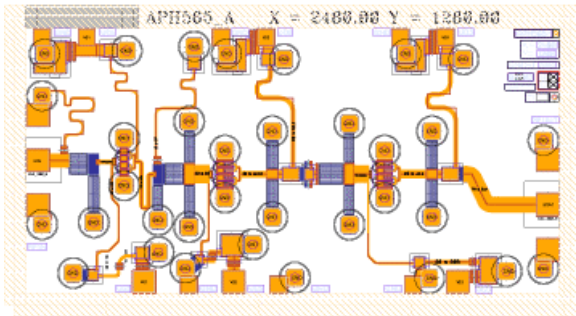

- Freq: 43 to 47 GHz
- Gain: 22 dB
- Biased for power:
  - $P_{1dB} = 24$  dBm (465 mW/mm), PAE > 22%
  - $P_{sat} = 24.7$  dBm (546 mW/mm), PAE > 24%

Biased for efficiency:

- $P_{1dB} = 23$  dBm (370 mW/mm), PAE > 30%
- $P_{sat} = 23.8$  dBm (450 mW/mm), PAE > 35%

- Size: 3.17 mm<sup>2</sup>

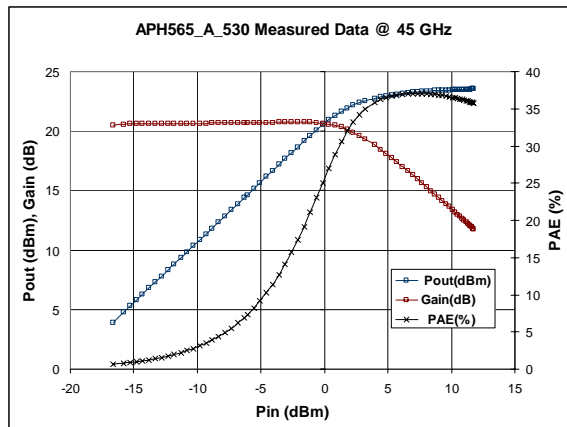
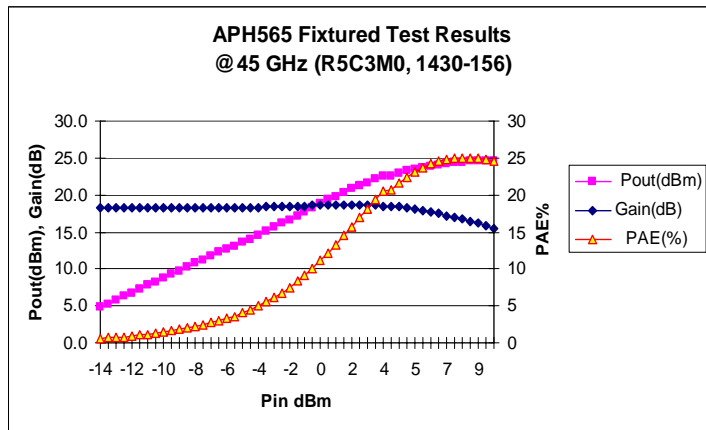

*Biased for Power*

*Biased for PAE*

**State-of-the-art  $P_{1dB}$  and PAE from 0.15um, 4mil GaAs process**

# Figure of Merit Comparison Table

Foundry	Year	Freq. (GHz)	Stages	Chip Size mm <sup>2</sup>	Output mm	S.S. Gain dB	P1dB dBm	PAE %	Psat dBm	Psat density mW/mm	OIP3 dBm	OIP3:P1dB	P1dB density mW/mm	OIP3 density W/mm
NGST	2003	19-21	2	2.5	0.8	18.5	24.0	30.0	25.9	<b>486</b>	35	<b>11</b>	<b>314</b>	<b>3.98</b>
Transcom	2002	14-17	4	4.1	3.6	30	30.8	24.5	31.3	375			333	
Triquint	2000	18-26	2	3.9	2.4	15	31.0	25.0	32	660	38.5	7.5	525	2.95
NGST	2003	24-27	2	5.9	2.4	19.5	30.9	24.0	31.6	<b>602</b>	40.5	<b>9.6</b>	<b>513</b>	<b>4.70</b>
NGST	2002	21-26	2	5.9	2.4	19.5	30.9	24.0	31	<b>525</b>	40.5	<b>9.6</b>	<b>513</b>	<b>4.70</b>
NGST	2003	30	1	1.9	2.4	10	31.0	25.7	32	<b>660</b>	40.5	<b>10</b>	<b>525</b>	<b>3.30</b>
UMS	2002	29	2	2.3	2.4	18.5	29.5		30.1	426.4			375	
Triquint	2002	30	4	12.9		22.5	34.5						219	
Triquint	2000	28-31	2	3.7	2.4	16	29.5	20.0	30.2	436.3	37	7.5	525	2.08
BAE	1999	29-33	2	14.9	10.8	18	34.8	20.0	36.5	413.6			280	
NGST	2003	37-40	2	4.5	2.16	15	30.0	18.0	31	<b>583</b>	41	<b>11</b>	<b>463</b>	<b>5.73</b>
NGST	2003	40-44	2	4.3	2.16	15	29.0	12.0	30.5	<b>519</b>	39	<b>10</b>	<b>368</b>	<b>3.64</b>
NGST	2003	43-47	3	3.2	0.54	22	24.0	35.0	24.8	<b>559</b>			<b>465</b>	

# CONCLUSIONS

- Demonstrated state of the art  $P_{1dB}$ ,  $P_{sat}$ , Power Density and  $OIP_3$  in compact die size.
- Meets high linearity requirements of phased array / radar transmitters.
  - High gain per stage enables excellent linearity, PAE and compact die size through 46 GHz.
  - Designs use NGST's flight qualified 0.15 $\mu$ m GaAs PHEMT technology.
  - NGST space qualified 0.15 $\mu$ m PHEMT with its proven track record of volume production and use in automated assembly will support high chip counts in large arrays.
- Next phase in design will reduce area by 50% while maintaining performance.