

# 100W QCW Laser Diode Array Submodule

## Part Number: ASM03P100

### SILVER BULLET™

- Packaged 2 Bar Laser Diode Array
- Easily Soldered to a Heat Exchanger
- Available Wavelengths (790-1550nm)

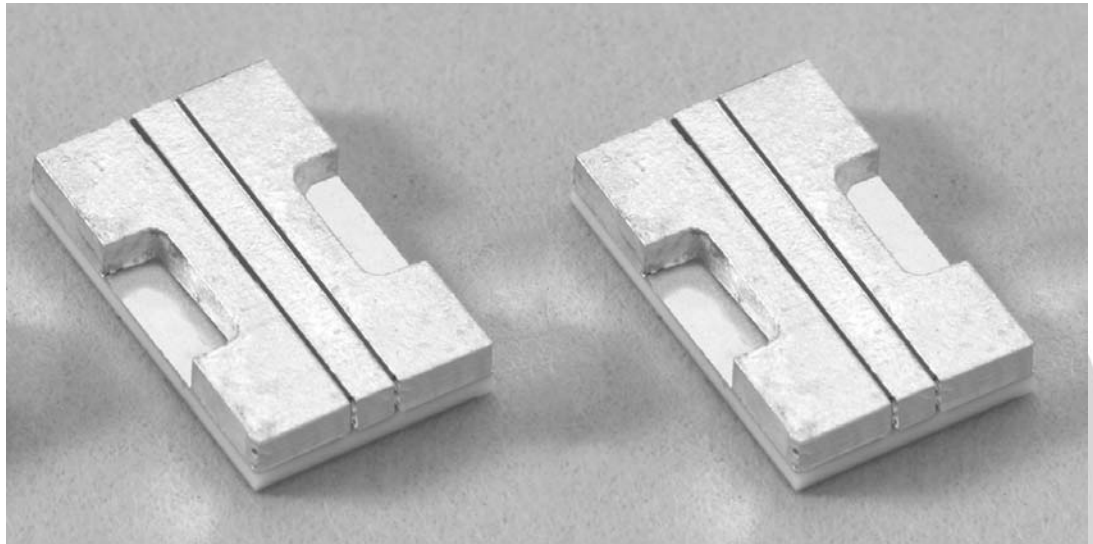

### OPTICAL CHARACTERISTICS

PARAMETER	CONDITIONS	MIN	TYP	MAX	UNITS
QCW Peak Power Output	65A, 150 μsec, 1kHz	100	---	---	W
Operating Current	100W at 25°C Heat Sink	---	55	65	A
Threshold Current	25°C Heat Sink	---	13	16	A
Center Wavelength	100W at 25°C Heat Sink	---	808	---	nm
Wavelength Tolerance	100W at 25°C Heat Sink	---	± 3	---	nm
Spectral Width	100W at 25°C Heat Sink	---	2.0	2.5	nm
Wavelength Shift	---	---	0.25	0.27	nm/°C
Beam Divergence FWHM	---	---	40x10	42x12	° x °

### ELECTRICAL CHARACTERISTICS

PARAMETER	CONDITIONS	MIN	TYP	MAX	UNITS
Series Resistance	25°C Heat Sink	---	0.012	0.020	ohms
Operating Voltage	25°C Heat Sink, 70W	---	3.8	5.4	V

### ABSOLUTE MAXIMUM RATINGS

PARAMETER	CONDITIONS
Forward Current	70A
Reverse Current	25μA
Reverse Voltage	3V
Operating Temperature Range <sup>(2)</sup>	-20°C to 50°C
Storage Temperature Range	-40°C to 85°C

#### NOTES

- (1) These specifications apply for operation at 808nm. Other wavelengths available upon request.
- (2) A dry nitrogen environment should be provided by the user when storing and operating at temperatures below ambient dew point.

# MECHANICAL CHARACTERISTICS

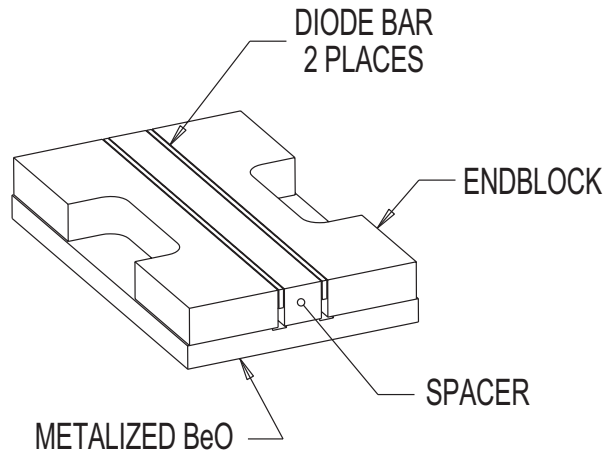
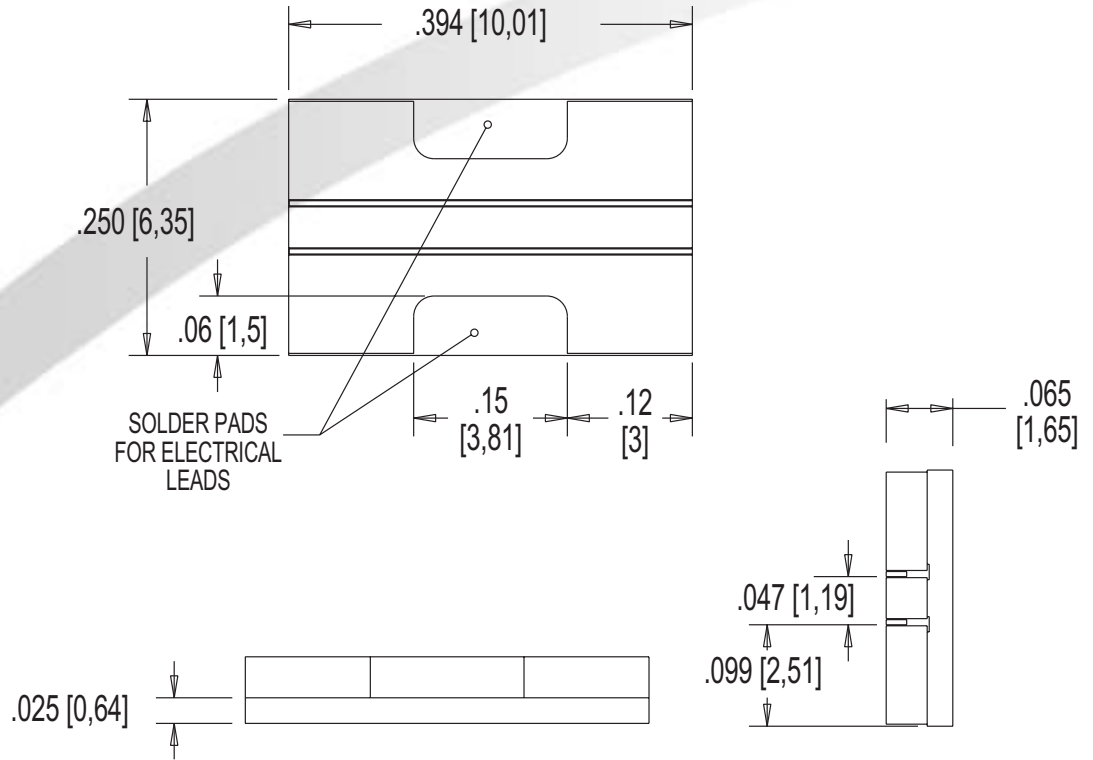

Copyright © 2003 Northrop Grumman Cutting Edge Optronics All Rights Reserved. Northrop Grumman Cutting Edge Optronics reserves the right to change product design and specifications at any time without notice.

No license is granted by implication or otherwise under any patents or patent rights of Northrop Grumman Cutting Edge Optronics or others.

No responsibility is assumed for the use of these products, nor for any infringement on the rights of others resulting from the use of these products.

Information contained herein is believed to be reliable and accurate.

This Product is covered by one or more of the following Patents: 5,898,211 5,985,684 5,913,108 6,310,900 Other US and Foreign Patents Pending.

Laser diode product components are intended for use in a user-devised end system. However, these products are capable of emitting Class IV radiation. Extreme care must be exercised during their operation. Only persons familiar with the appropriate safety precautions should operate a laser product. Directly viewing the laser beam or exposure to specular reflections must be avoided. Serious injury may result if any part of the body is exposed to the beam. The eye is extremely sensitive to the infrared radiation and therefore, proper eyewear must be worn at all times. Use of optical instruments with these products may increase eye hazard. Always wear proper eye protection when operating.

**DANGER**

INVISIBLE LASER RADIATION

AVOID EYE OR SKIN EXPOSURE TO DIRECT OR SCATTERED RADIATION

Diode laser  
5W & up, 790-1560nm  
CLASS IV

**WARNING**

ELECTROSTATIC DISCHARGE SENSITIVE DEVICE REQUIRING SPECIAL HANDLING



Rev B 02/04

**NORTHROP GRUMMAN**

*Space Technology*

**Cutting Edge Optronics**

20 Point West Blvd. St. Charles, MD 63301 636.916.4900 p 636.916.4994 f

[www.st.northropgrumman.com/ceolaser](http://www.st.northropgrumman.com/ceolaser) [st-ceolaser-info@ngc.com](mailto:st-ceolaser-info@ngc.com)