

# 45W Lensed CW Laser Diode Array

## Part Number: LAR23C045

### E2 PACKAGE

- CW powers up to 320W
- QCW powers up to 600W
- Higher powers and custom configurations available
- Available Wavelengths (790-1550nm)

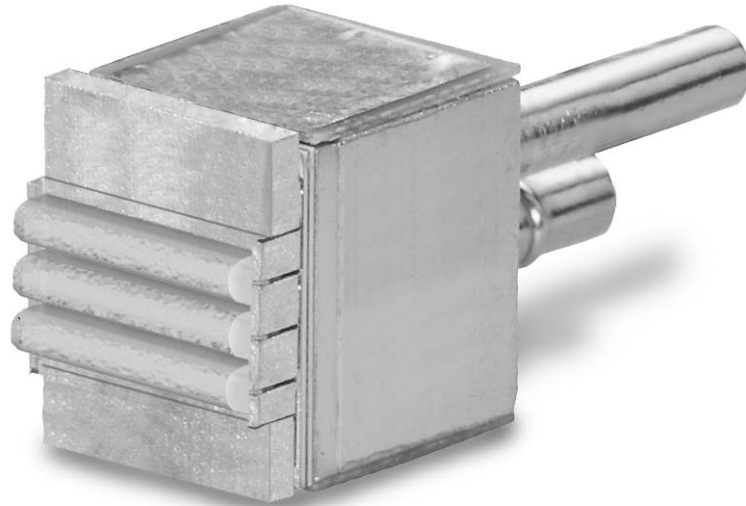

### OPTICAL CHARACTERISTICS

PARAMETER	CONDITIONS	MIN	TYP	MAX	UNITS
CW Power Output	30A at 25°C Heat Sink <sup>(1)</sup>	45	---	---	W
Operating Current	45W at 25°C Heat Sink	---	28	34	A
Threshold Current	25°C Heat Sink	---	7.5	9.0	A
Slope Efficiency	25°C Heat Sink	2.7	3.3	---	W/A
Efficiency	45W at 25°C Heat Sink	28	42	---	%
Number of Emitters per bar <sup>(2)</sup>	---	---	46 x 3	---	
Bar Pitch	---	0.8	1.9	3.2	mm
Emitter Size <sup>(2)</sup>	---	---	80 x 1	---	µm
Emitter Pitch <sup>(2)</sup>	---	---	200	---	µm
Center Wavelength <sup>(3)</sup>	45W at 25°C Heat Sink	792	808	812	nm
Wavelength Tolerance <sup>(3)</sup>	45W at 25°C Heat Sink	± 1	± 3	± 4	nm
Spectral Width	45W at 25°C Heat Sink	---	3.1	4.0	nm
Wavelength Shift	---	0.23	0.25	0.27	nm/°C
Beam Divergence FWHM	---	---	3 x 10	---	° x °
Polarization	---	---	TE	---	---
Degradation Rate <sup>(4)</sup>	25°C Heat Sink	---	3	---	%/kHr

### ELECTRICAL CHARACTERISTICS

PARAMETER	CONDITIONS	MIN	TYP	MAX	UNITS
Built-in Voltage	25°C Heat Sink	---	4.8	5.1	V
Series Resistance	25°C Heat Sink	---	0.015	0.036	ohms
Operating Voltage	25°C Heat Sink, 45W	---	5.4	6.3	V

#### NOTES

(1) Lower beam divergence is also available.

(2) Typical degradation rates are 5% in the first 100 hours and 3% per 1,000 hours thereafter.

(3) These specifications apply for operations at 808nm. Other wavelengths available upon request.

**NORTHROP GRUMMAN**  
Space Technology

Cutting Edge Optonics

20 Point West Blvd. St. Charles, MO 63301 636.916.4900 p 636.916.4994 f  
www.st.northropgrumman.com/ceolaser st-ceolaser-info@ngc.com

# MECHANICAL CHARACTERISTICS

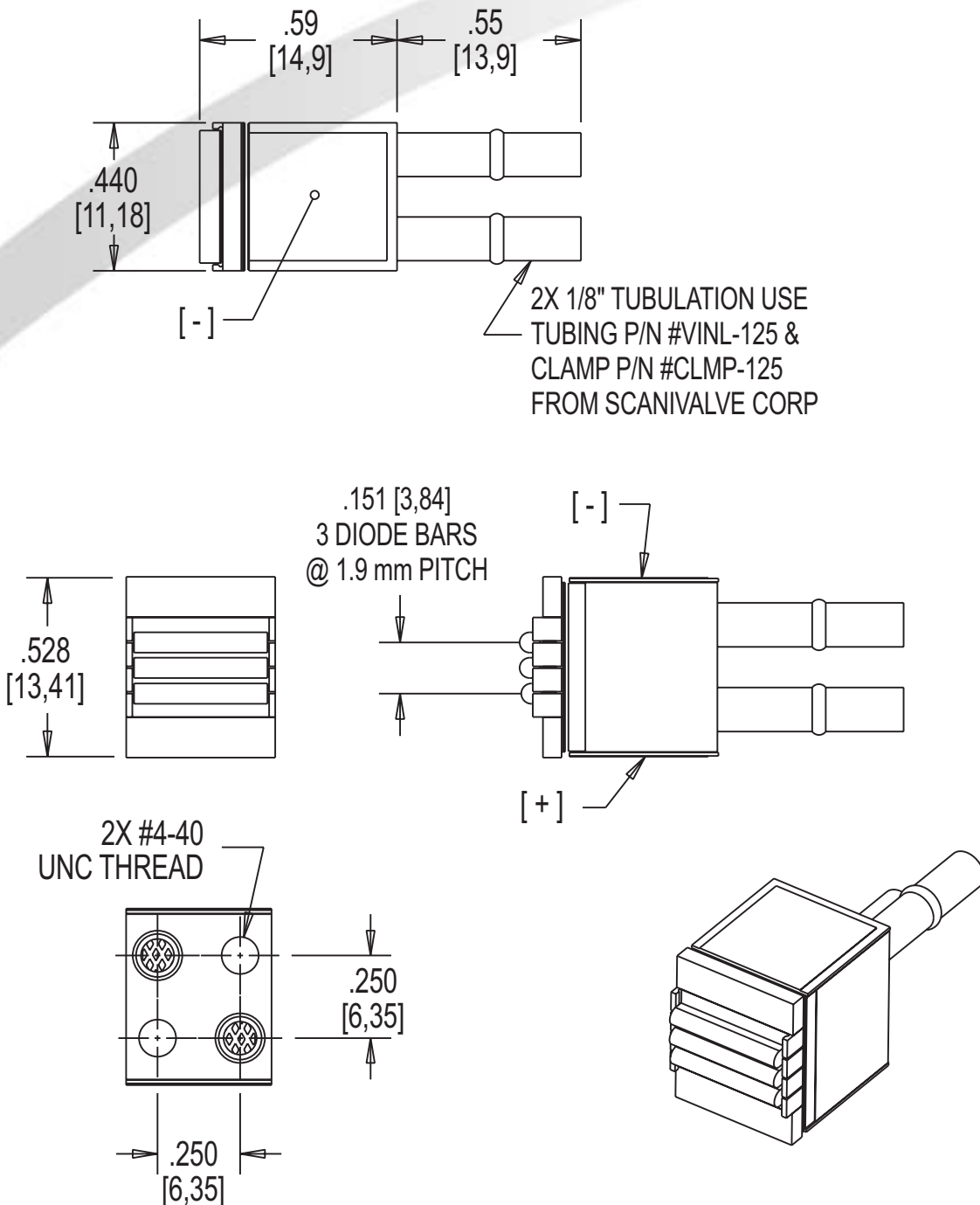

Copyright © 2003 Northrop Grumman Cutting Edge Optronics All Rights Reserved. Northrop Grumman Cutting Edge Optronics reserves the right to change product design and specifications at any time without notice.

No license is granted by implication or otherwise under any patents or patent rights of Northrop Grumman Cutting Edge Optronics or others.

No responsibility is assumed for the use of these products, nor for any infringement on the rights of others resulting from the use of these products.

Information contained herein is believed to be reliable and accurate.

This Product is covered by one or more of the following Patents: 5,898,211 5,985,684 5,913,108 6,310,900 Other US and Foreign Patents Pending.

Laser diode product components are intended for use in a user-devised end system. However, these products are capable of emitting Class IV radiation. Extreme care must be exercised during their operation. Only persons familiar with the appropriate safety precautions should operate a laser product. Directly viewing the laser beam or exposure to specular reflections must be avoided. Serious injury may result if any part of the body is exposed to the beam. The eye is extremely sensitive to the infrared radiation and therefore, proper eyewear must be worn at all times. Use of optical instruments with these products may increase eye hazard. Always wear proper eye protection when operating.

**DANGER**

INVISIBLE LASER RADIATION  
AVOID EYE OR SKIN EXPOSURE TO DIRECT OR SCATTERED RADIATION

\* Diode laser  
5W & up, 790-1560nm  
CLASS IV

**WARNING**

ELECTROSTATIC DISCHARGE SENSITIVE DEVICE  
REQUIRING SPECIAL HANDLING



Rev B 02/04

**NORTHROP GRUMMAN**  
*Space Technology*

**Cutting Edge Optronics**

20 Point West Blvd. St. Charles, MD 63301 636.916.4900 p 636.916.4994 f

www.st.northropgrumman.com/ceolaser st-ceolaser-info@ngc.com